

Indoor battery-less temperature and humidity sensor for Bluetooth Low Energy

Authors:

M. Meli, U. Beerli

Contact address:

Prof. Dr. Marcel Meli

Zürcher Hochschule für Angewandte Wissenschaften (ZHAW)

Institute of Embedded Systems (InES)

Technikumstrasse 9

CH-8400, Winterthur, Switzerland

Email : marcel.meli@zhaw.ch

Abstract:

In June 2010, the Bluetooth SIG adopted the first version of Bluetooth that includes the low energy specifications (4.0). Ble has been designed to allow devices running on a small energy budget to communicate with host stations such as mobile phones or personal computers. Bluetooth low energy is primarily meant to be used in applications that require small batteries. In this work we investigated the suitability of that new wireless protocol for a battery-free application. We chose a simple and yet useful application scenario, where temperature and humidity are measured in an office environment and the results are wirelessly sent to a host. The use of the new sensor SHT21 from Sensirion allows temperature and humidity to be precisely measured with a small energy budget. For sensors to be moved and placed conveniently, a wireless system based on the EM9301 Ble radio of EM Microelectronic is implemented. The EM6819 is used as microcontroller to control the system. Energy autonomy is provided by a flexible and small solar cell from G24i. Temperature and humidity data can be displayed or transferred to the right place by using the appropriate PC or mobile phone fitted with the wireless link. As far as we know, this is the first work of this type using a battery-less sensor and Ble for communication.

1. Introduction and description of the issues.

The last years have seen an important proliferation of wireless protocols, all claiming to be well (if not best) suited for low power. A related aspect has been that of energy autonomy. It is often desirable to have sensors that can be powered by energy harvesting.

All these wireless protocols certainly have good reasons behind their development, but they will clearly not all be equally successful. An important issue in establishing a protocol is the market it addresses and the available basis. Ble builds on the well-known Bluetooth standard. BT classic can already be found in millions of devices, including smart phones and personal computers. It is expected that the next generations of mobile devices will integrate a dual solution, capable of communicating with BT classic (say for voice applications) and with Ble (for low energy low data rate applications). [2]

In order to address the low energy sensor issue, the designers of Ble had to deal with important issues such as channel access, interferences, frame length ... etc. In these respects, the new protocol is quite different from many low energy technologies. To allow a certain "compatibility" with BT classic and therefore reduce the cost of the so call Dual Mode, Ble also had to make some compromises.

In a Ble network, sensors advertise their services on up to 3 channels, chosen to minimize the impact of other 2.4 GHz sources such as wireless LAN. Exchange of data is mainly done in connected mode, using 37 other channels. In connected mode, more information needs to

be exchanged, at least when the communicating parties are negotiating the connection parameters. It is therefore obvious that communication in connected mode places more energy demands on devices, compared to systems where all data can be sent at once (in 1 frame). To reduce energy needs, one can take advantage of advertisement frames that contain data.

The benefits of using wireless and battery-free devices are well known. There are several examples based on proprietary and standards wireless protocols [3, 4, 6, 7, 9, 13]. How suitable is Ble when battery-less devices are used? Can the new standard allow the millions of hosts that will be integrated in smart phones or PCs to serve as gateways for devices powered by scavenged energy?

In this work we use an available Ble transceiver to try to answer the question about the suitability of Ble for battery-free applications, especially in when they are powered by small solar cells.

2. The design

In order to explore the issues mentioned above, we designed a temperature and humidity sensor for an office environment. The sensor should be small, cheap and be powered by a solar cell. It should be able, at normal office times, to regularly (at least every minute) measure the needed parameters, and send the data to a host in the office for display.

2.1. Hardware

Figure 1 shows the blocks needed in the application.

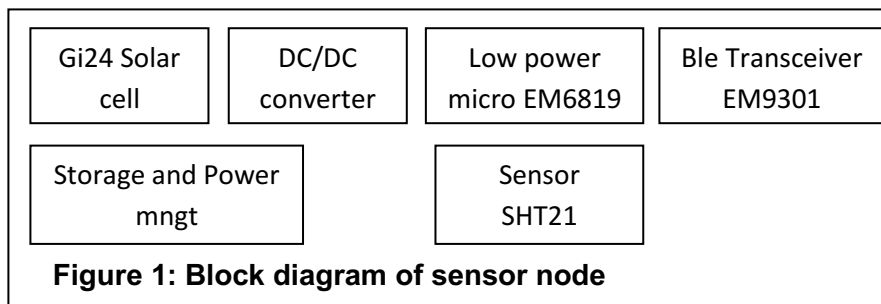

An important step in designing for low energy is the choice of appropriate components. The elements of the sensor are chosen to use a minimum of energy in order to measure and send the messages, since they should be powered only by a small solar cell in office luminosity conditions. Components are also selected to keep costs down. The different components will now be described.

EM9301 [5,10]

The EM9301 is used in this application to transmit Ble radio frames to a host station. It is a single-mode Master/Slave controller optimized for low voltage and low energy systems such as wireless sensors, wireless remote controls and wireless monitoring. With operating

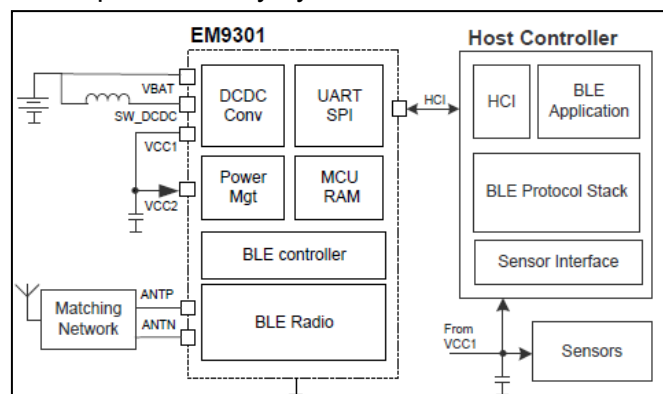

supply voltage as low as 0.8V, the circuit allows applications to take advantage of a wide range of common single-cell batteries or of energy harvesters such as solar cells, piezo-electric and electro-magnetic elements. The output power can be programmed between -20dBm and +4 dBm. The device typically needs 14.5 mA in active mode (radio on).

EM6819 [14]

This microcontroller is based on the 8-bit CoolRISC CPU. It can start as low as 0.9 volt, and consumes around 140µA @ 1MIPS, 3 volts. It is used in this application to control the temperature sensor and the radio. Its low energy timer can also be used to time events.

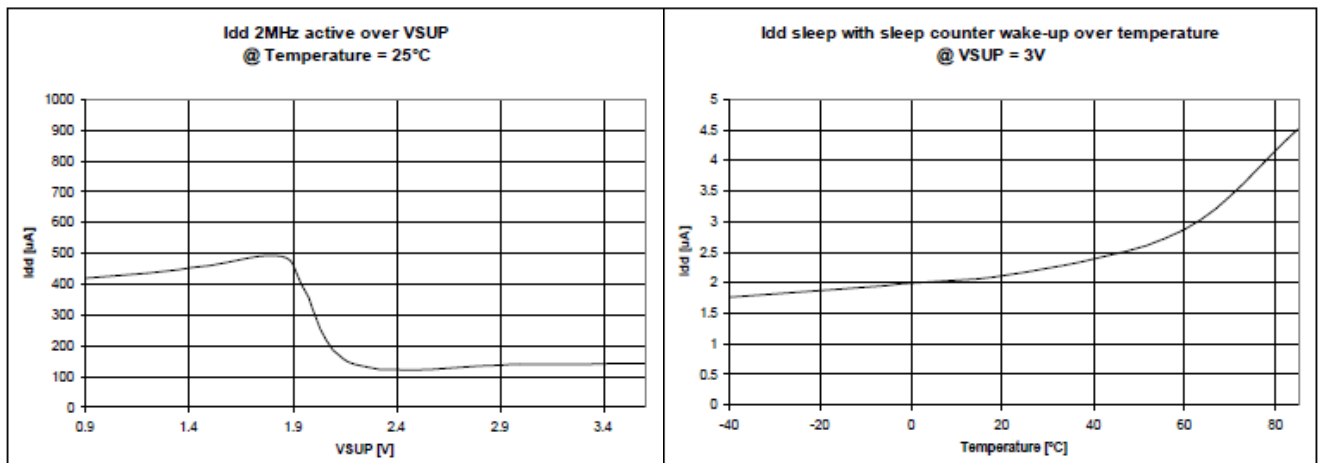

Figure 3: current consumption of the microcontroller

SHT21 [8]

This is an extremely small, fully calibrated relative humidity and temperature sensor. It is fitted with a serial bus (2-wire) for communication with a host controller.

At 3.6 volts, the device consumes a maximum of 330µA in active mode and 0.4µA in sleep mode. The device needs up to 15ms to start up, consuming a maximum of 350µA (2.1volts to 3.6 volts) in that phase.

The measurement time depends on the resolution and the type of measurement, as shown in the Table 1.

Resolution	RH typ	RH max	T typ	T max	Units
14 bit			66	85	ms
13 bit			33	43	ms
12 Bit	22	29	17	22	ms
11 bit	12	15	9	11	ms
10 bit	7	9			ms
8 bit	3	4			ms

Table 1: Measurement time against resolution

Solar Cell [12]

Several solar cells were tested, in particular those of the firm G24i.

An effort was made to use small cells to keep costs and space needs down. The Indy2050 is used for the measurements shown in this work. It measures 35mm x 50mm. Its important parameters are shown in Table 2.

Parameter	Symbol	Condition	Typical	Minimum	Maximum	Units
Open circuit voltage	Voc	200 lux	1.12	1.10	1.13	V
		1000 lux	1.25	1.24	1.27	
Short circuit current	Isc	200 lux	57	52	63	µA
		1000 lux	253	242	265	
Operating voltage	Vop	200 lux	0.89	0.87	0.91	V
		1000lux	1.00	0.97	1.03	
Operating current	Iop	200 lux	51	46	55	µA
		1000 lux	228	215	241	
Bend radius	Br	-	30	-	-	mm
Thickness	d	-	0.35	-	-	mm
Mass	M	-	592	-	-	gm ²

Table 2: Important parameters of the Indy2050 solar cell

Voltage conversion and energy management.

This block is responsible for delivering a voltage that is high enough for the electronics to function properly until the measurements and the transmission are done. It consists of a DC/DC converter circuit, followed by a voltage monitor and a capacitor for storing the energy. The step-up allows the use of a minimum number of solar cells and, in this way, contributes in keeping costs low. The voltage monitor circuit allows the embedded system to be started only if enough energy has been accumulated to carry out the tasks of measuring and communicating. The capacitor has to be chosen such as to allow the system to work well within the limits given by the manufacturers.

A solution based on a device that starts up early and manages the storage is possible for this block. This will come in form of a special converter combined with a storage management device, or a low power microcontroller (state machine) that can start on little energy and implement the needed control functions.

In our system, the 0.3 volt delivered by the solar cell is enough to start up the voltage converter and store energy. A timer could also be used (in the EM6819 or with an external low power RTC) to time the sampling activities. More information can be found in works done earlier [13].

Costs

We estimate the combined costs of the main components described earlier at less than \$5 (10K pieces). This will of course vary with quantities. The manufacturers should be contacted for the exact costs.

2.2. Communication

The strategy for communication is chosen to favour low power. It allows data to be sent with a minimum of software and information overhead in the communication frames. Ble allows data to be sent between devices that are "in connected mode", or between an advertiser and a scanner. In this application, the best strategy is to send data in advertisement frames. The host will then read the data that directly include temperature information. Since a connected mode is not needed, a minimum of frames is sent (only one with the necessary overhead). The drawback is that the information is broadcasted, and not directed to a specific host.

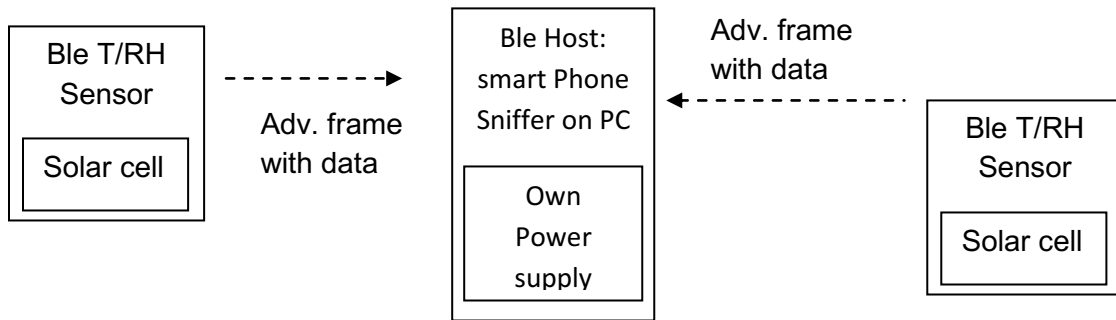

Figure 4: Sensors and host

The elements required in the frame while sending data in advertising mode are shown in Table 3. One could send the data on all 3 ADV channels or only on one of them. More information about the frame format and the timings to meet can be found in the Ble specifications [1].

	lsb						msb
LL packet format	Preamble (1 octet)	Access address (4 octets)	PDU (2 to 39 octets)			CRC (3 octets)	
Access address	10001110100010011011111011010110b (0x8E89BED6) (this is the access address of all adv. Packets)						
Adv. PDU format				Header (16-Bit)	Pload (length in header)		
Header of ADV PDU	PDU type (4 bits)	RFU (2 bits)	TxAdd (1 bit)	RxAdd (1 bit)	Length (6 bits)	RFU (2 bits)	
PDU type ADV_NONCONN_IND	0100 (b0 ... b3)						
Payload ADV_NONCONN_IND					ADVA (6 octets)	ADV Data (0-31 octets)	

Table 3: Elements needed in the sent frame

In this application, the temperature and humidity data of the sensors have been coded in 2 times 2 bytes = 4 bytes. The packet sent is formatted as Table 4.

Format of frame used to send data					
Preamble	Access adr	Header	ADVA	ADV data	CRC
1 octet	4 octets (0x8E89BED6)	2 octets	6 octets	4 octets (2 for T, 2 for RT)	3 octets

Table 4: Final format of the frame

2.3. Software

The software is written to allow an efficient use of energy. It starts and stops different blocks at the right time, in order to make use of sleep and power down modes as often as possible. It should also allow the system to recover/restart properly in case there are energy problem.

The software will control the selection of channels and the timings to respect the specifications. For example, in case only 1 ADV channel is chosen to send data, it should be check that minimal time between ADV events is respected.

3. Tests and results

In order to test the design a node was built using the elements described earlier.

The node was placed in our office, and programmed to start every time that sufficient energy has been accumulated to be able to carry out measurements and transmit data. As receiving station, a Ble node based on the CC2540 device from Texas Instruments running the Ble protocol in a sniffer mode was used. Sniffed data were displayed on a personal computer. The sensor node was used in different illumination conditions.

Data from the sensor node was transmitted using one advertisement channel, and the receiver set to receive in 2 different ways:

- First on exactly the same channel with no rotation to cover the other 2 advertisement channels
- Then to receive on all advertisement channels, one after the other.

3.1. Energy profile

Figure 5 shows the dynamic energy profile of the sensor node.

The system current and the voltage are shown over the time. Since the energy is first accumulated in a capacitor before starting, the voltage progressively decreases as the capacitor is emptied.

The total energy used by the system is around 138 μ J, with the transceiver working at +4dBm, and 20 bytes sent (counting the preamble as a byte).

When the system starts, the decoupling capacitors are first charged, leading to a peak in the current. The microcontroller, sensor and radio that are directly connected to VDD also start up. After the POR, the EM6819 microcontroller boots up and initialises the SHT21. It then orders temperature to be measured, and goes in a low power mode for a given time (chosen to be enough for the SHT21 to complete the measurement with the selected resolution). After completion of temperature measurement, the SHT21 goes in a low power mode. The microcontroller wakes up, reads the temperature, and gives the order to the sensor to measure the humidity. It then goes in a low power mode for a defined time, while the sensor carries out the task. After humidity has been measured, the results are read by the microcontroller which will then prepare the data to be sent and initialise the radio. This initialisation happens over the HCI interface, and costs a lot of energy. The radio executes the necessary operations, starts transmission, and stops when the microcontroller orders it.

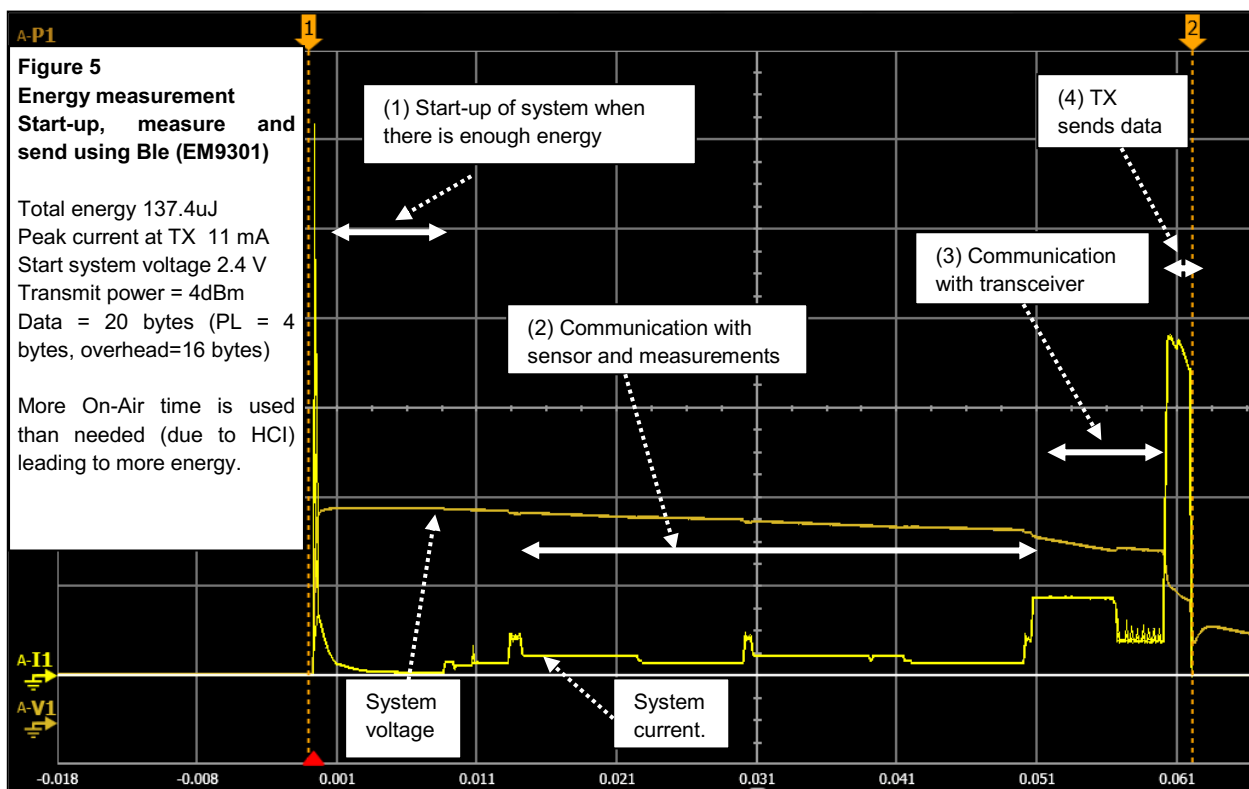

3.2. Receiving data on advertisement channels

With the receiver working on the same channel as the sensor node, nearly all packets sent were received. Figure 6 shows a typical sniffer output. The time difference between the frames is related to the luminosity in the office. The higher the luminosity, the more energy is accumulated in a shorter time. Data is then sent more often.

If the receiver is made to scan all the 3 advertisement channels, about one third of the messages are received. If the sensor is programmed to send on all channels, more energy needs to be accumulated first. This can be done by increasing the capacitor where energy is accumulated. It will result in sending less telegrams.

As pointed out earlier, measurements of temperature and humidity in an office environment do not have to occur very often. A measurement every minute will be more than enough. In this case, it is no great penalty to accumulate more energy and to send data on the 3 advertisement channels.

Texas Instruments SmartRF Packet Sniffer Bluetooth Low Energy													
File Settings Help													
P.nbr.	Time (us)	Channel	Access Address	Adv PDU Type	Adv PDU Header				AdvA	AdvData	CRC	RSSI (dBm)	FCS
					Type	TxAdd	RxAdd	PDU-Length					
1	+0 =0	0x26	0x8E89BED6	ADV_NON_CONN_IND	2	0	0	10	0x123456789ABC	6F C0 6D 3B	0x345CBE	-42	OK
2	+11162933 =11162933	0x26	0x8E89BED6	ADV_NON_CONN_IND	2	0	0	10	0x123456789ABC	6F C0 6F FF	0x5FBCD7	-42	OK
3	+9354283 =20517216	0x26	0x8E89BED6	ADV_NON_CONN_IND	2	0	0	10	0x123456789ABC	69 80 69 CB	0x830A00	-42	OK
4	+9596026 =30113242	0x26	0x8E89BED6	ADV_NON_CONN_IND	2	0	0	10	0x123456789ABC	6F 60 68 EF	0xBEE635	-42	OK
5	+9970638 =40083880	0x26	0x8E89BED6	ADV_NON_CONN_IND	2	0	0	10	0x123456789ABC	6F 3C 68 8B	0xEF8F88	-42	OK
6	+9705755 =49789635	0x26	0x8E89BED6	ADV_NON_CONN_IND	2	0	0	10	0x123456789ABC	6F 3C 69 1B	0x99F23C	-42	OK
7	+9849539 =59639174	0x26	0x8E89BED6	ADV_NON_CONN_IND	2	0	0	10	0x123456789ABC	6F 1C 69 AF	0xA41F0A	-42	OK
8	+9856157 =69495331	0x26	0x8E89BED6	ADV_NON_CONN_IND	2	0	0	10	0x123456789ABC	6F 1C 69 1B	0x55780A	-42	OK
9	+10469565 =79964896	0x26	0x8E89BED6	ADV_NON_CONN_IND	2	0	0	10	0x123456789ABC	6E FC 6C 23	0x0F92FC	-41	OK

Figure 6 : Data sent by sensor was captured using a sniffer. The field “AdvData” shows temperature and humidity data in hexadecimal. Data is sent every 10 seconds (depends on luminosity)

Conclusions and future work

We have shown in this work that it is possible to use the Ble wireless standard in combination with energy harvesting.

For a meaningful application, temperature and humidity were measured in an office environment using a very small solar cell. In order to allow the system to use as less energy as possible, low power transceivers and sensors were chosen. Care was taken to avoid unnecessary software overhead. For communication, data was sent in Advertising mode, allowing the sensor node to use minimal energy. In that mode, one can use all 3 channels which will increase the probability of the data being received, but at the cost of using more energy.

A future work will seek to further minimise the energy need by optimising the firmware. A storage element will also be considered to extend the usefulness of the node to periods where less luminosity is available.

Acknowledgements

We wish to express our thanks to the following firms for their help and support:

- EM Microelectronic Marin, Switzerland for providing microcontrollers and Ble radios
- Sension AG Stäfa, Switzerland for providing sensors
- The Texas Instrument team in Switzerland for providing Ble kits
- G24i in Wales for providing solar cell samples.

References.

- [1] Ble specifications V 4.0, June 2010
<https://www.bluetooth.org/Technical/Specifications/adopted.htm>
- [2] Bluetooth SIG www.bluetooth.org
- [3] A battery-less switch for use in 802.15.4 / ZigBee applications
M. Meli, A. Bluem, M. Gysel. Second European Developer's ZigBee Conference.
Munich June 2009
- [4] Bidirectional 868/915 MHz wireless module powered with energy harvester.
M. Meli, S. Blättler, V. Kunz, M. Gysel
10. Wireless Technologies Kongress, September 2008, Bochum
- [5] EM9301 factsheet. http://www.emmarin.com/webfiles/product/other/EM9301_FS.pdf
- [6] EnOcean: www.enocean.com
- [7] lightningswitch: www.lightningswitch.com
- [8] ST21 datasheet. www.sensirion.ch
- [9] Battery-less wireless Switch with EM9201. www.ines.zhaw.ch
- [10] Datasheet and development tools for CC2540. www.ti.com
- [11] EM news about the EM9301. <http://www.emmarin.com/DetailNews.asp?IdNews=123>
- [12] Indy2050 solar cell datasheet. www.q24i.com
- [13] ZigBee compatible sensor powered by one tiny solar cell
M. Würms, M. Gysel, M. Meli; 4th European ZigBee Conference
Munich April 2010
- [14] EM6819 datasheet.
http://www.emmarin.com/webfiles/product/mcu/ds/EM6819_DS.pdf